

REVISIONS			
REV	DATE	DESCRIPTION	DWN
A	10/2/18	RELEASED	JAB
B	11/29/22	UPDATED SHEET FORMAT	JMV
C	5/19/23	ADDED G55 CONTOUR	JMV

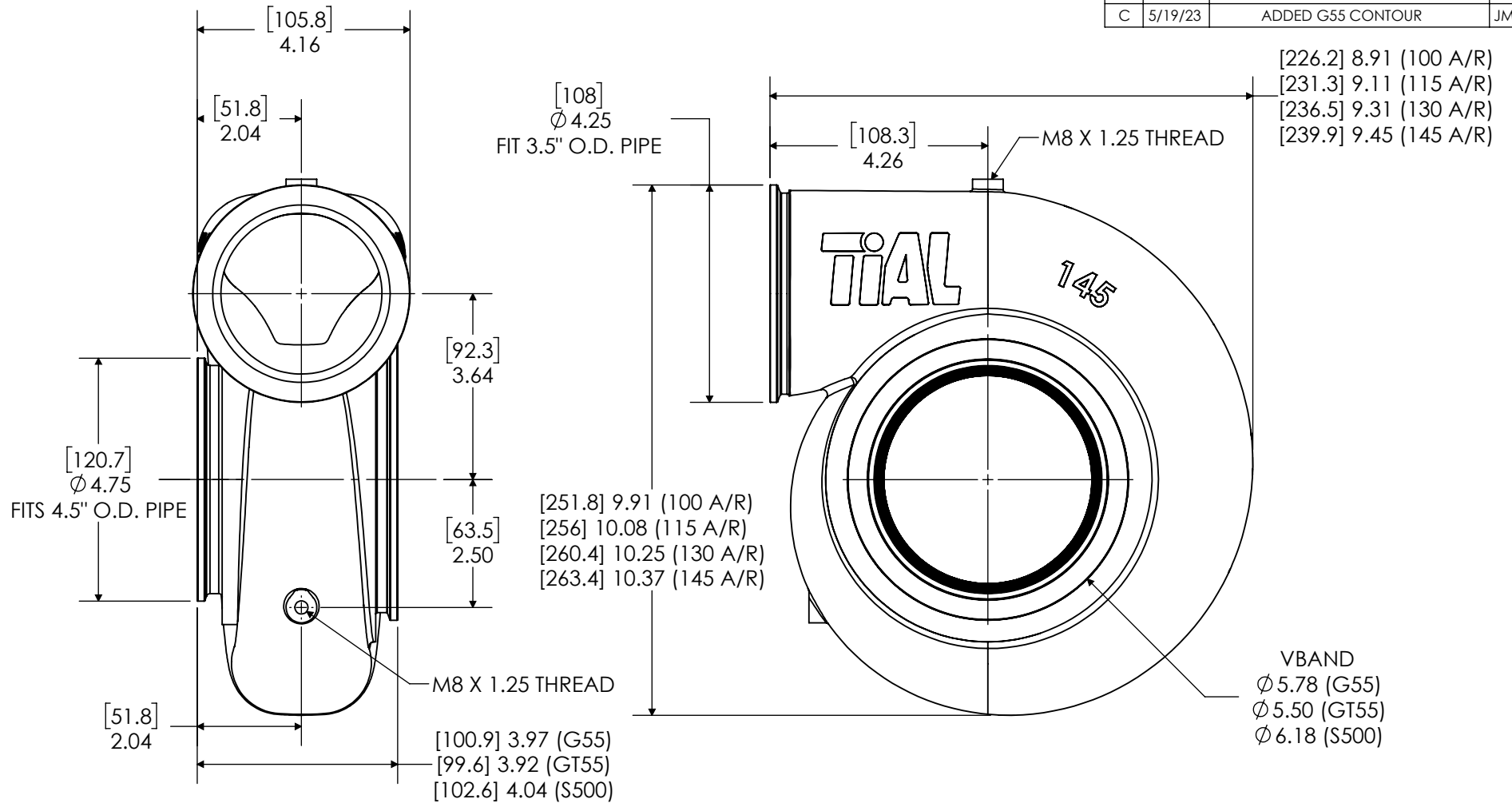

A/R	CONTOUR	PART NUMBER
100	G55	008660
	GT55	006422
115	G55	008661
	GT55	002470
130	S500	006428
	G55	008662
145	GT55	003404
	S500	006429
145	G55	008663
	GT55	006423
	S500	006430

PROPRIETARY AND CONFIDENTIAL
 THE INFORMATION CONTAINED IN THIS DRAWING IS THE SOLE PROPERTY OF TIAL PRODUCTS. ANY REPRODUCTION IN PART OR AS A WHOLE WITHOUT THE WRITTEN PERMISSION OF TIAL PRODUCTS IS STRICTLY PROHIBITED.

UNLESS OTHERWISE SPECIFIED: ANGULAR DIMENSIONS ARE IN DEGREES DO NOT SCALE DRAWING		PART DESCRIPTION TIAL VB 55 BW S500	
SIZE A	PART NO. SEE CHART	REV C	
PROJECT NUMBER: 2022-047			
MATERIAL STAINLESS STEEL	DRAWN BY: JMV	DATE DRAWN: 11/29/22	CHECKED BY: AJE
		DATE CHECKED: 12/12/22	SHEET: 1 OF 1