

* P/N* DENOTES REVERSE ROTATION AVAILABLE

REVISIONS			
REV	DATE	DESCRIPTION	DWN
A	10/2/18	RELEASED	JAB
B	11/29/22	UPDATED SHEET FORMAT	JMV
-	-	-	-

A/R	CONTOUR	PART NUMBER
63	GT35	*002463*
	GT36	BY REQUEST
	GT37	003426
	SUPER 76	BY REQUEST
	S300	BY REQUEST
	XR55	007227
	XR57S	008182
	XR64	*005419*
	XR64S	006875
	XR65	005427
	XR67	005497
	XR68	BY REQUEST
XR69S	006878	
82	GT35	*002464*
	GT36	004454
	GT36	003038
	SUPER 76	004696
	S300	004915
	XR55	BY REQUEST
	XR57S	008181
	XR64	*005420*
	XR64S	006876
	XR65	005426
	XR67	005498
	XR68	*005429*
XR69S	006879	
103	GT35	*002461*
	GT36	004587
	GT37	002462
	SUPER 76	004663
	S300	004916
	XR55	BY REQUEST
	XR57S	008180
	XR64	*005417*
	XR64S	006877
	XR65	005411
	XR67	005418
	XR68	*005428*
XR69S	006880	

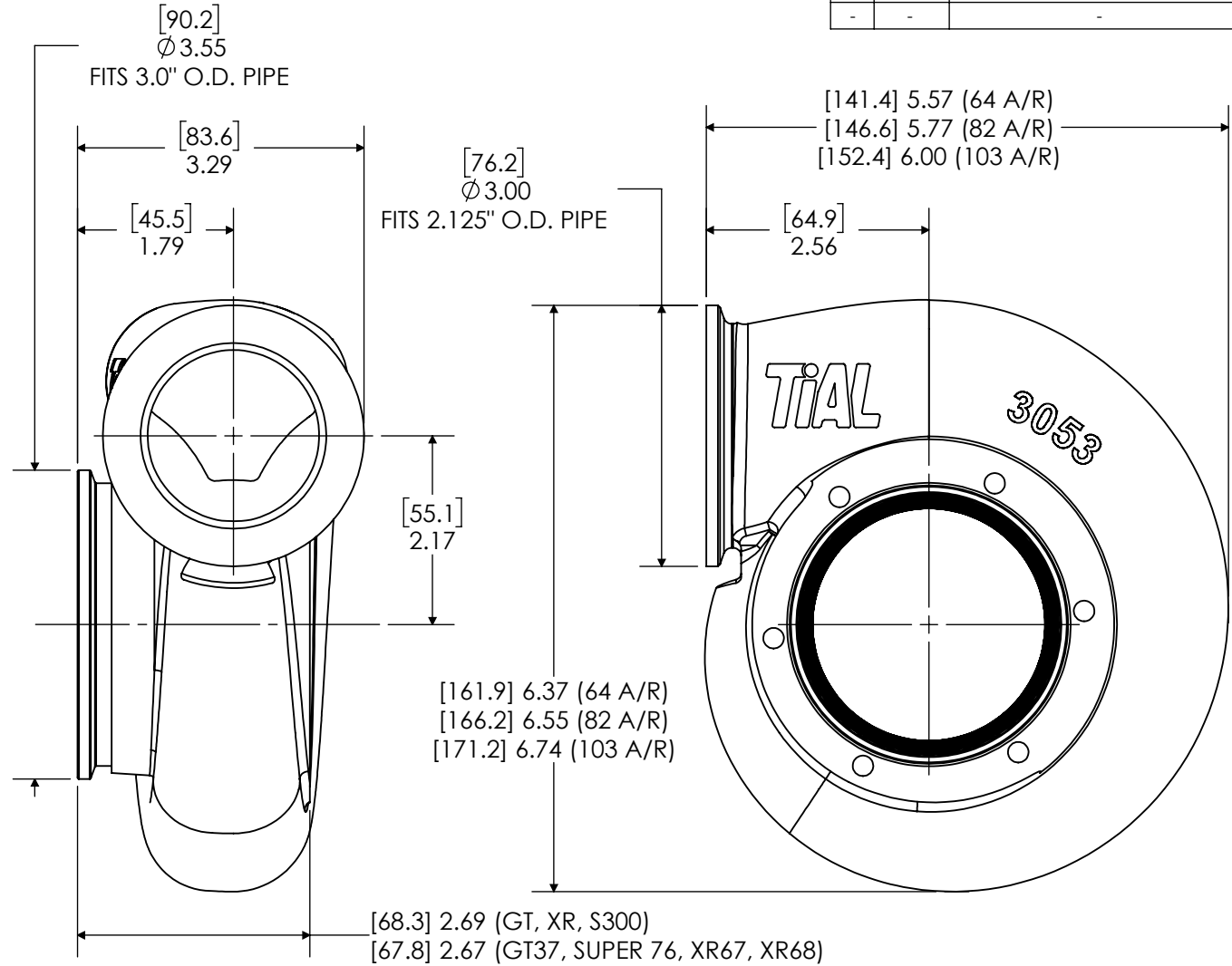

PROPRIETARY AND CONFIDENTIAL
THE INFORMATION CONTAINED IN THIS DRAWING IS THE SOLE PROPERTY OF TIAL PRODUCTS. ANY REPRODUCTION IN PART OR AS A WHOLE WITHOUT THE WRITTEN PERMISSION OF TIAL PRODUCTS IS STRICTLY PROHIBITED.

	TIAL PRODUCTS 450 S. SHIAWASSEE, OWOSSO, MI 48867		
	PART DESCRIPTION TIAL VB 35, 36, 37, SUPER 76, S300 XONA XR 57S, 64, 64S, 65, 67, 67S, 68, 69S		
UNLESS OTHERWISE SPECIFIED: ANGULAR DIMENSIONS ARE IN DEGREES DO NOT SCALE DRAWING	SIZE A	PART NO. SEE CHART	REV B
PROJECT NUMBER: 2022-047			
MATERIAL STAINLESS STEEL	DRAWN BY: JMV	DATE DRAWN: 11/29/22	CHECKED BY: AJE
		DATE CHECKED: 12/9/22	SHEET: 1 OF 1