

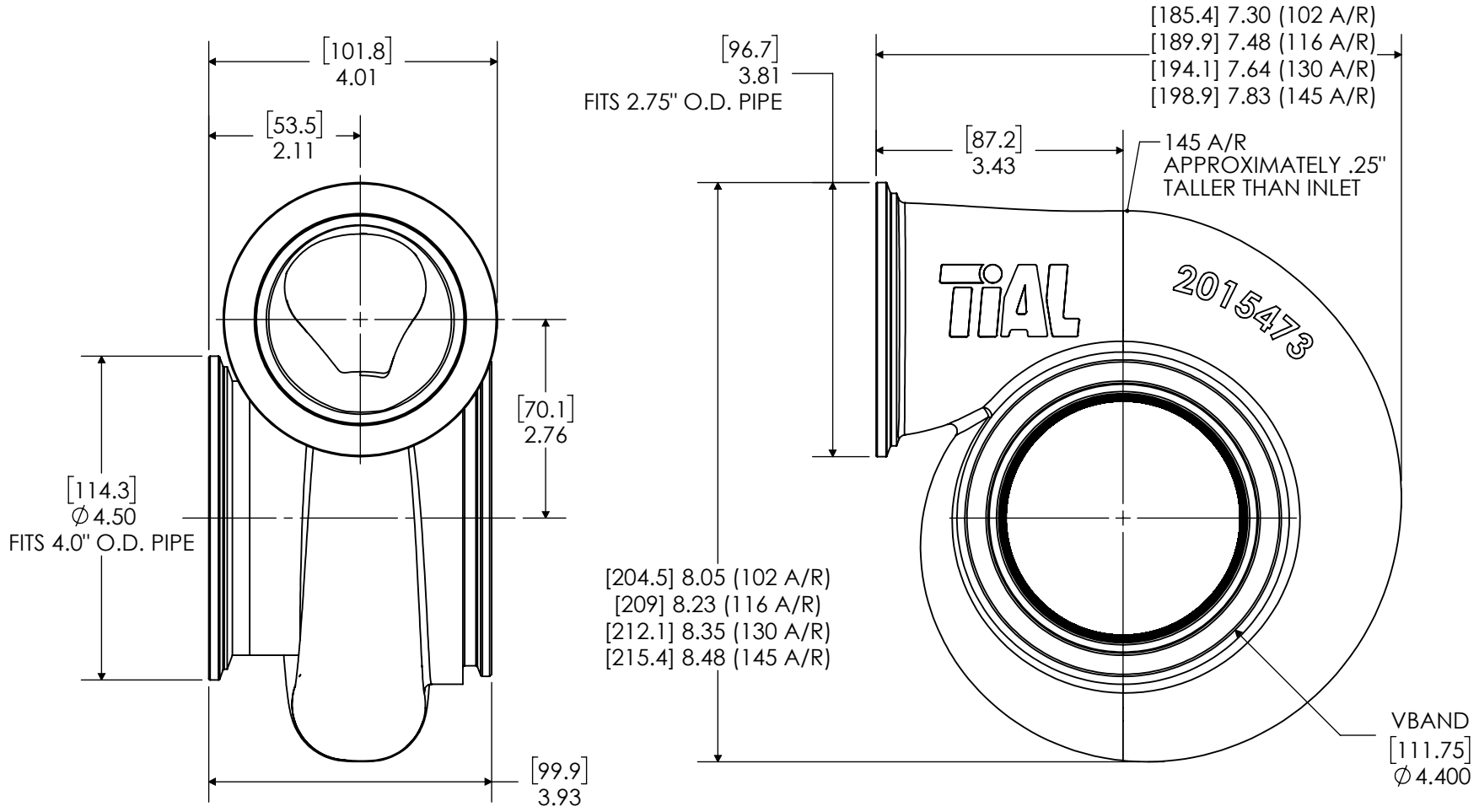

REVISIONS			
REV	DATE	DESCRIPTION	DWN
A	10/4/18	RELEASED	JAB
B	12/10/22	UPDATED SHEET FORMAT	JMV
-	-	-	-

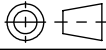

A/R	CONTOUR	PART NUMBER
102	S400 83MM	004830
	S400 87MM	004831
116	S400 83MM	004829
	S400 87MM	004827
130	S400 83MM	004832
	S400 87MM	004833
145	S400 83MM	BY REQUEST
	S400 87MM	BY REQUEST

PROPRIETARY AND CONFIDENTIAL
 THE INFORMATION CONTAINED IN THIS DRAWING IS THE SOLE PROPERTY OF TIAL PRODUCTS. ANY REPRODUCTION IN PART OR AS A WHOLE WITHOUT THE WRITTEN PERMISSION OF TIAL PRODUCTS IS STRICTLY PROHIBITED.

 TIAL PRODUCTS 450 S. SHIAWASSEE, OWOSSO, MI 48867			
UNLESS OTHERWISE SPECIFIED: ANGULAR DIMENSIONS ARE IN DEGREES DO NOT SCALE DRAWING		PART DESCRIPTION TIAL BW S400 83MM & 87MM	
SIZE A	PART NO. SEE CHART	REV B	
PROJECT NUMBER: 2022-047			
MATERIAL STAINLESS STEEL	DRAWN BY: JMV	DATE DRAWN: 12/10/22	CHECKED BY: AJE
		DATE CHECKED: 12/12/22	SHEET: 1 OF 1