

- NOTES:  
 1) ROD SHOWN AT MAXIMUM RETRACT  
 2) FULL STROKE IS 0.75"  
 3) ADD FULL STROKE TO EXPOSED ROD TO CALCULATE FULL EXTENSION  
 4) KEEP IN MIND EXTENDING MORE OF THE ROD CHANGES SPRING PACK PRELOAD

REVISIONS			
REV	DATE	DESCRIPTION	DWN
A	1/18/21	RELEASED	EAS
B	12/22/22	UPDATED SHEET FORMAT	ALM
-	-	-	-

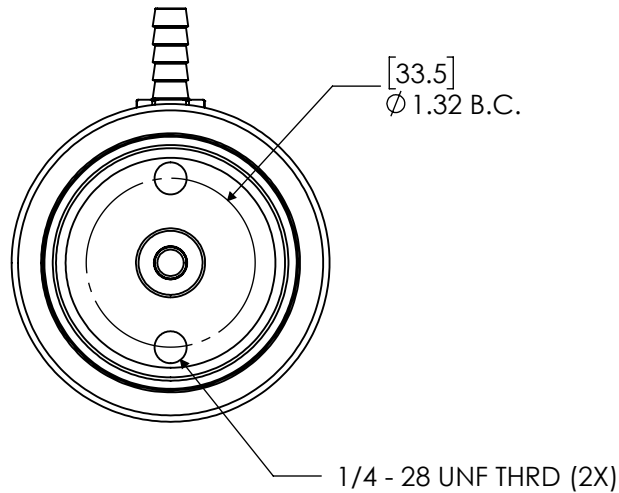
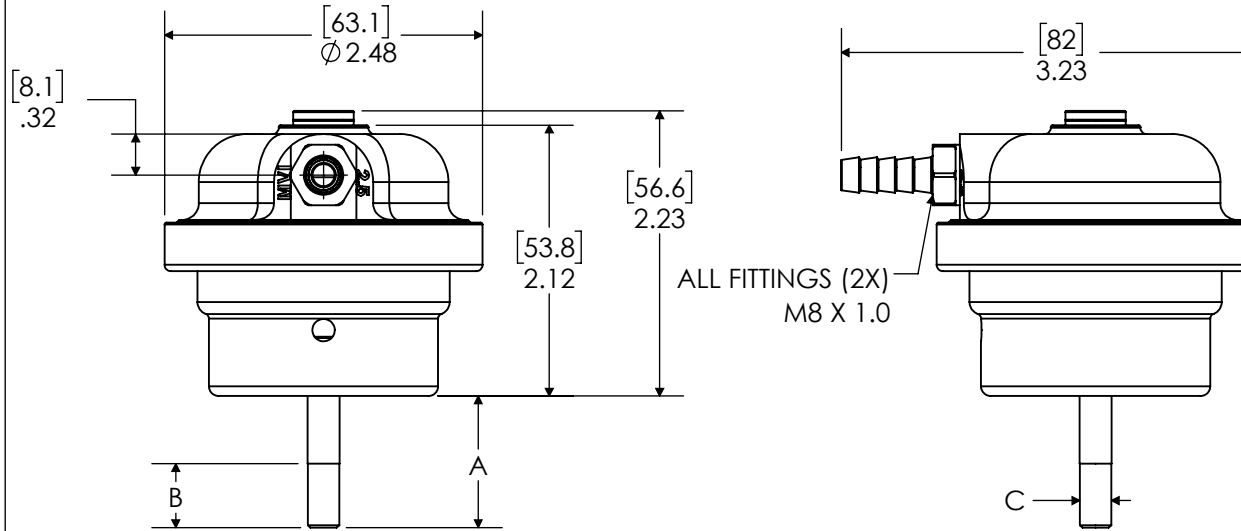

ROD P/N	DIM A	DIM B	DIM C (THRD)	TOTAL ROD LENGTH
007604	[26.2] 1.03	[12.7] 0.50	1/4 - 28	[66.8] 2.63
002079	[54.6] 2.15	[32.0] 1.26	1/4 - 28	[95.3] 3.75
002080	[70.6] 2.78	[32.0] 1.26	1/4 - 28	[111.3] 4.38
005252	[69.3] 2.73	[20.3] 0.80	1/4 - 28	[110.0] 4.33
005988	[167.6] 6.60	[32.0] 1.26	1/4 - 28	[208.3] 8.20
005989	[182.1] 7.17	[32.0] 1.26	1/4 - 28	[222.8] 8.77
006574	[192.0] 7.56	[32.0] 1.26	1/4 - 28	[232.6] 9.16
006939	[89.2] 3.51	[59.9] 2.36	M6 x 1.0	[129.8] 5.11
006940	[125.0] 4.92	[59.9] 2.36	M6 x 1.0	[165.6] 6.52
006941	[144.3] 5.68	[59.9] 2.36	M6 x 1.0	[184.7] 7.27
006942	[162.3] 6.39	[59.9] 2.36	M6 x 1.0	[203.2] 8.00
007002	[144.5] 5.69	[38.1] 1.50	1/4 - 28	[185.2] 7.29
007438	[105.4] 4.15	[32.0] 1.26	1/4 - 28	[146.1] 5.75
007652	[219.7] 8.65	[32.0] 1.26	1/4 - 28	[260.4] 10.25

UNLESS OTHERWISE SPECIFIED:			
ANGULAR DIMENSIONS ARE IN DEGREES			
DO NOT SCALE DRAWING			
PART DESCRIPTION		REV	
MVI 2.5 PUBLIC		B	
SIZE	PART NO.	PROJECT NUMBER: 2022-117	
A	SEE CHART		
MATERIAL	DRAWN BY:	DATE DRAWN:	CHECKED BY:
	ALM	12/22/22	AJE
		DATE CHECKED:	12/22/22
			SHEET: 1 OF 1

PROPRIETARY AND CONFIDENTIAL  
 THE INFORMATION CONTAINED IN THIS DRAWING IS THE SOLE PROPERTY OF TIAL PRODUCTS.  
 ANY REPRODUCTION IN PART OR AS A WHOLE WITHOUT THE WRITTEN PERMISSION OF TIAL  
 PRODUCTS IS STRICTLY PROHIBITED.