

REVISIONS			
REV	DATE	DESCRIPTION	DWN
A	7/12/22	RELEASED	ALM
-	-	-	-
-	-	-	-

NOTES:
 1) xxxxxxxxxxxxxxxx
 2) xxxxxx

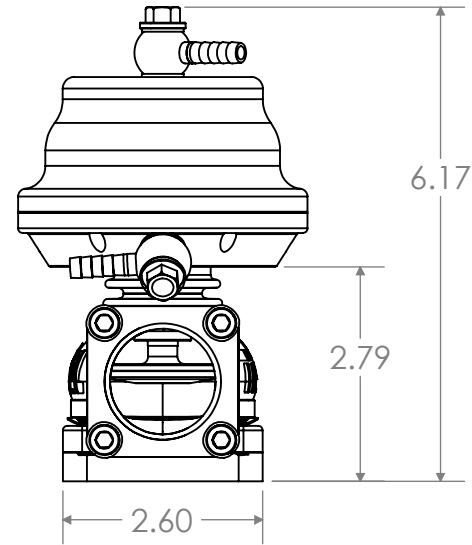

1.22
BACK OF
CASTING REF

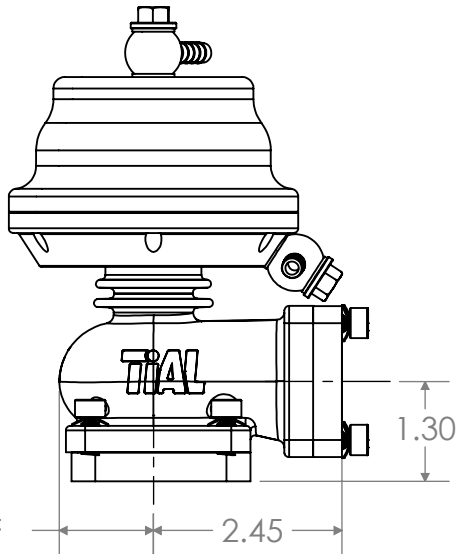
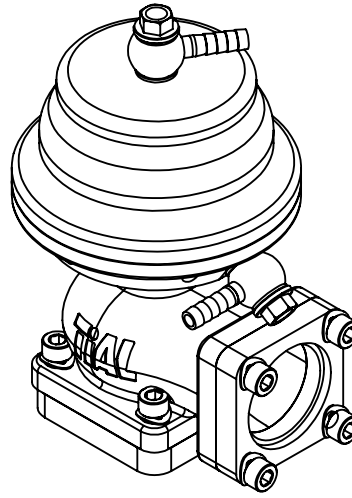
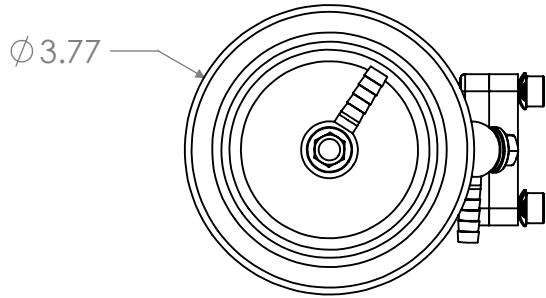
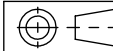

TIAL PRODUCTS
 450 S. SHIAWASSEE
 OWOSSO, MI 48867



UNLESS OTHERWISE SPECIFIED:
 DIMENSIONS ARE IN INCHES
 ANGULAR DIMENSIONS ARE IN DEGREES

TOLERANCES:
 .XX ± .01
 .XXX ± .005
 .XXXX ± .001
 ANGULAR: ± .5 DEG
 EDGE/CORNER BREAKS .015
 FILLET RADII .015
 MAX SURFACE ROUGHNESS 125 Ra
 DO NOT SCALE DRAWING

PART DESCRIPTION			
F41 PUBLIC			
OP#	TYPE		
SIZE	PART NO.	REV	
A		A	
PROJECT NUMBER:			
DRAWN BY:	DATE DRAWN:	CHECKED BY:	DATE CHECKED:
ALM	7/12/22	XXX	2/26/19
			SHEET: 1 OF 1

PROPRIETARY AND CONFIDENTIAL
 THE INFORMATION CONTAINED IN THIS DRAWING IS THE SOLE PROPERTY OF TIAL PRODUCTS.
 ANY REPRODUCTION IN PART OR AS A WHOLE WITHOUT THE WRITTEN PERMISSION OF TIAL
 PRODUCTS IS STRICTLY PROHIBITED.

MATERIAL